

WATER-TIGHT SUMP BLADDER KITS



SPECIFICATIONS:

- ***BLADDER:** HEAVY HIGH NITRILE RUBBER.
- ***COMPRESSION RING:** 3 PIECE PLATED, INTERLOCKING DUCTILE IRON RING.
- ***EXPANSION RING:** HEAVY DUTY 2 PIECE PLATED, INTERLOCKING STEEL RING.
- ***FIBERGLASS SUMPS ARE THE ONLY ONES THAT CAN BE RETROFITTED.**

FEATURES:

- *KEEPS HIGH GROUND WATER FROM OVERFLOWING INTO THE SUMP.
- *DOES NOT REQUIRE TOP HAT SUMP COVER.
- *BY USING THE RETROFIT MANHOLE COVER WITH THE CAM-LOK OBSERVATION PORT, THERE IS NO NEED TO REMOVE THE 36" COVER AND ALL INSPECTIONS CAN BE PERFORMED THROUGH THIS AREA.
- *BEST OF ALL, IT CUTS DOWN ON MAINTENANCE COSTS.

NOTE: MANHOLE SKIRT IS SOLDERED AT THE SEAMS TO MAKE IT TOTALLY WATER-TIGHT

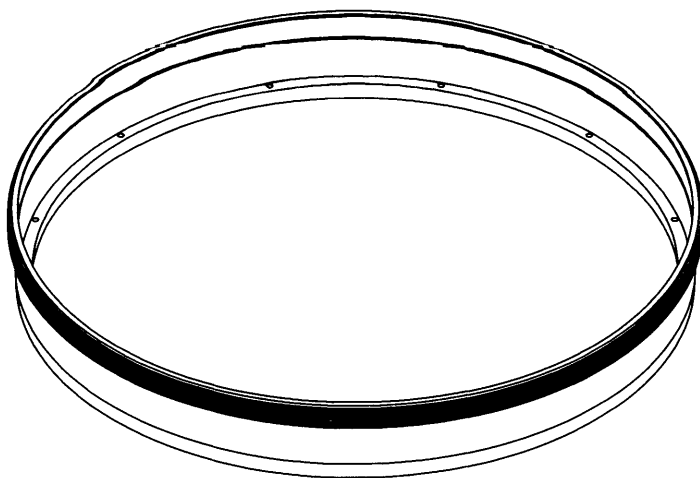

RUBBER BLADDER KITS FOR EXISTING FIBERGLASS SUMPS.

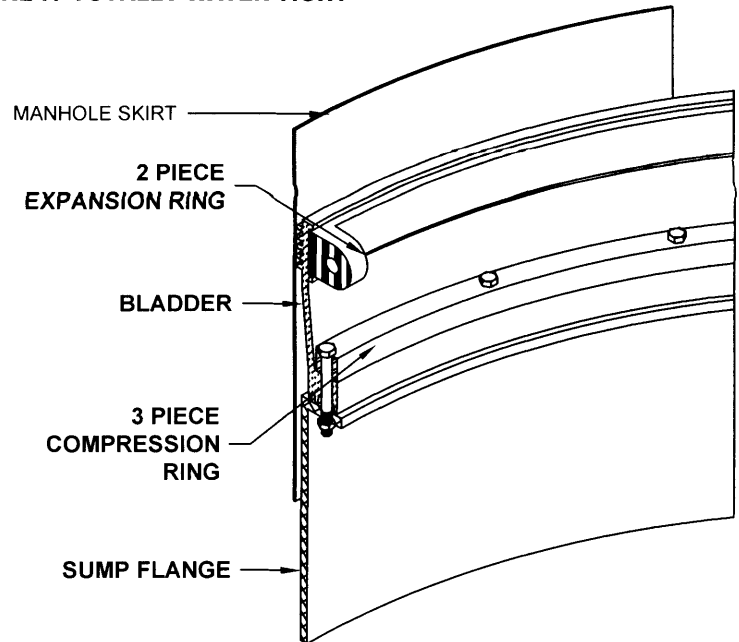

CROSS-SECTION

INCLUDES: BLADDER, EXPANSION RING, COMPRESSION RING AND SUMP FLANGE.

DESCRIPTION	PART #
FOR A 36" MANWAY	36 33 34 NI
FOR A 42" MANWAY	42 39 40 NI
FOR A 48" MANWAY	48 46 47 NI

NI = NEW INSTALLATION

PART NUMBER LEGEND:

MANHOLE SIZE	TOP HAT	SUMP SIZE
36"	33"	34"

